

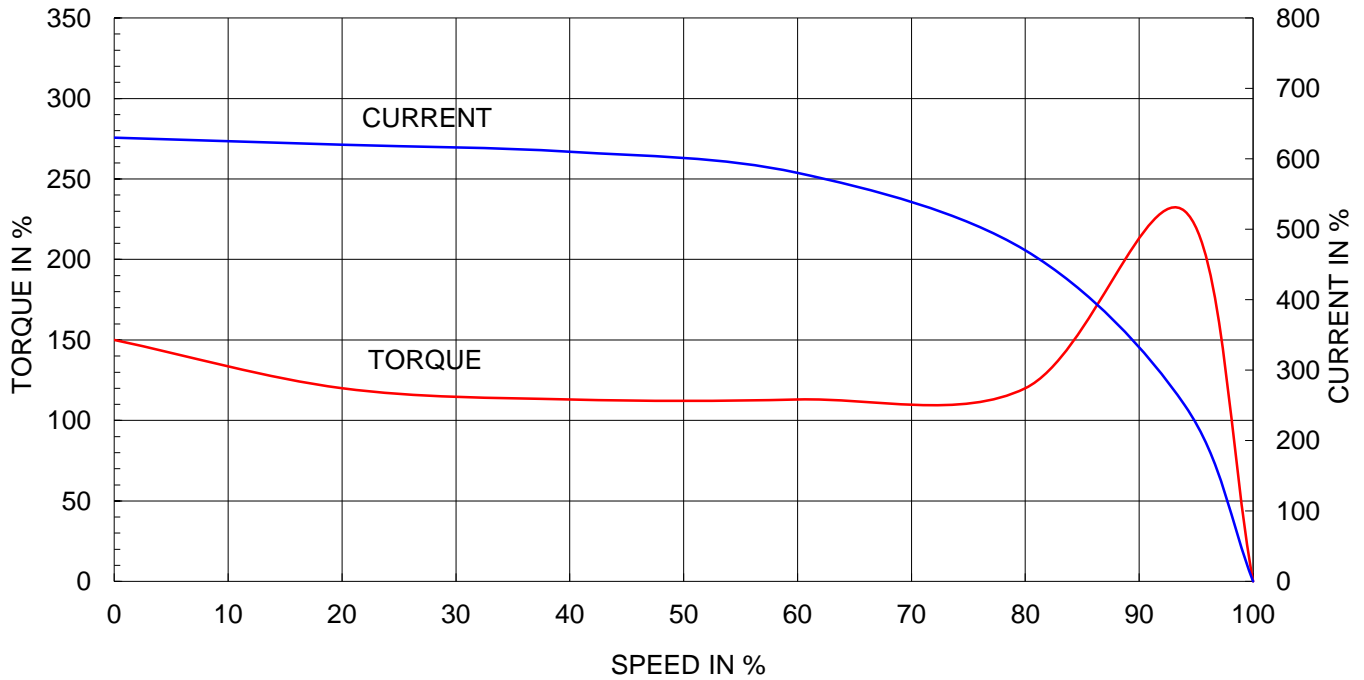

Type :	HS
Full Load Torque :	37.0 Kg.m
Motor moment of Inertia (J) :	1.555 Kg.m <sup>2</sup>
Load moment of Inertia (J) :	101.050 Kg.m <sup>2</sup>

45 kW	6 P	60 Hz
Speed at Full Load :		1185 RPM
Rated Voltage	440V	380V
Full Load Current	75.6A	87.5A

SPEED VS TORQUE & CURRENT CURVE



OUTPUT VS EFF., P.F & CURRENT CURVE

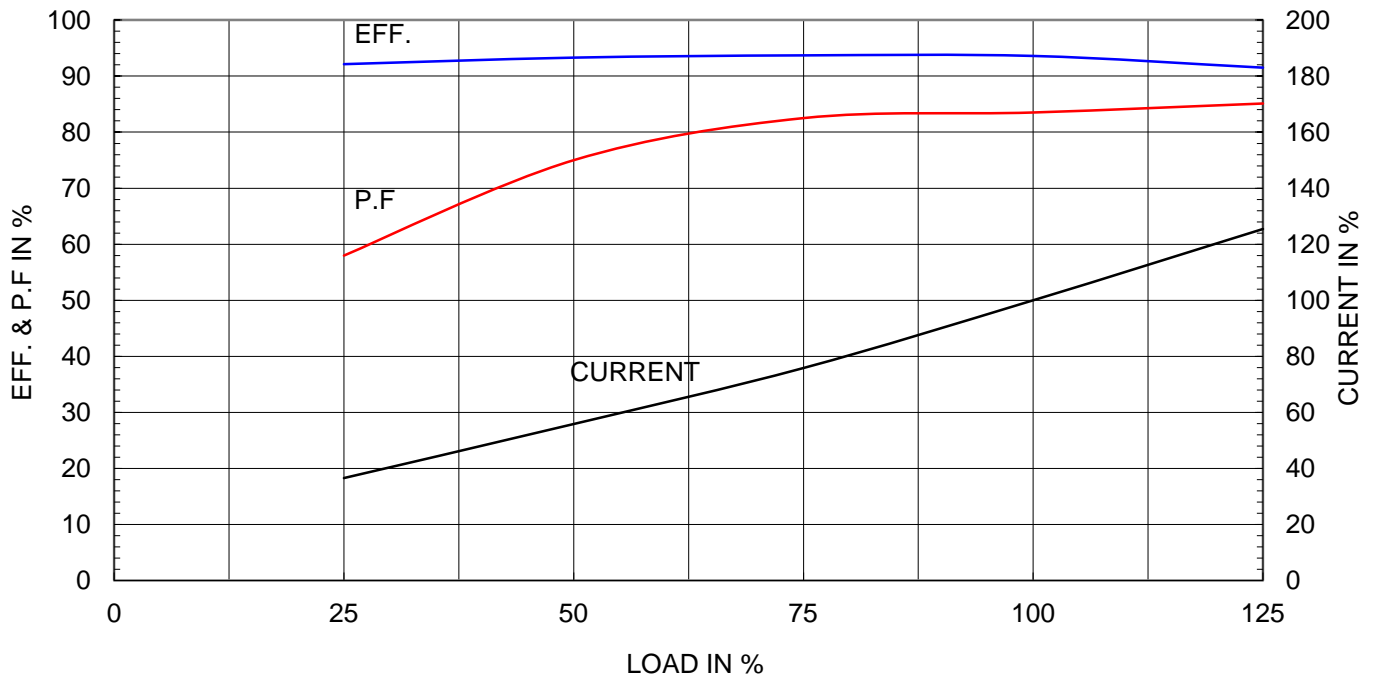

본 도면은 현대중공업(주) 재산이므로  
허가없이 복사할 수 없음 (취급유의)

THIS DRAWING IS PROPRIETARY TO HHI. NO PART OF THIS DRAWING  
MAYBE REPRODUCED WITHOUT THE PERMISSION OF HHI.

		<h1>TEFC</h1>		<b>TYPE</b> (1) TNB , TDB CAST IRON FRAME
		<b>THREE PHASE INDUCTION MOTOR</b>		

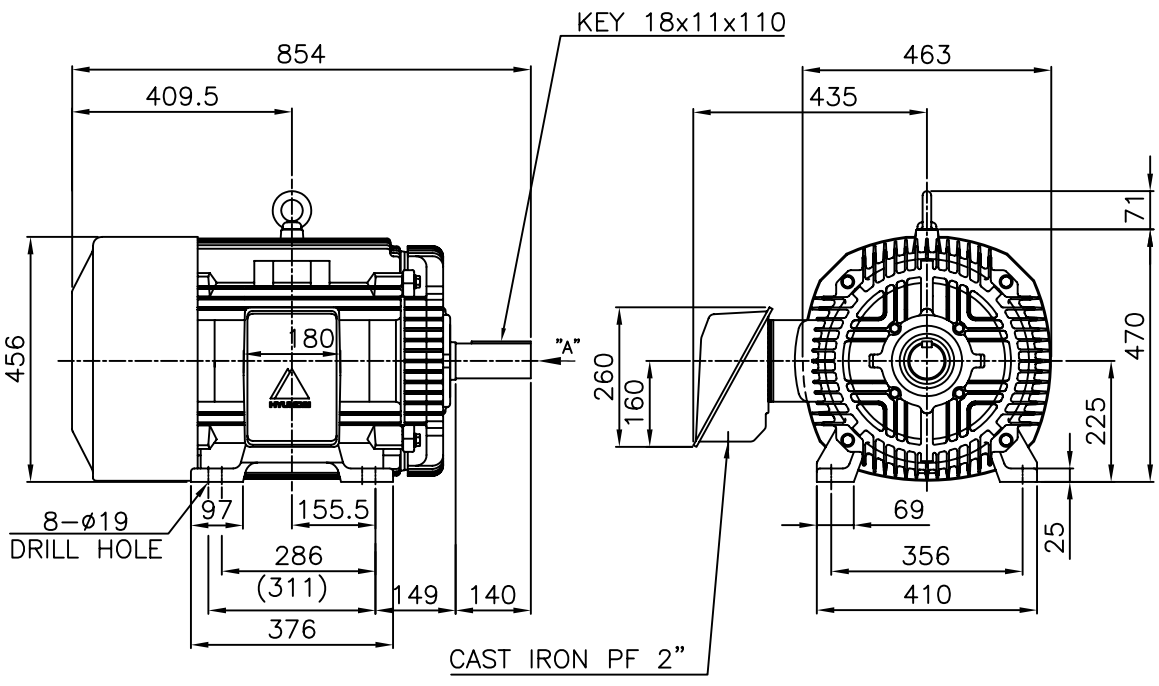

**NOTE**

1. TOLERANCE :

CENTER HEIGHT	225	$\begin{matrix} 0 \\ -0.5 \end{matrix}$
BASE HOLE	$\phi 19$	$\begin{matrix} +0.43 \\ 0 \end{matrix}$
SHAFT DIAMETER	$\phi 65$	$\begin{matrix} +0.030 \\ +0.011 \end{matrix}$
KEYWAY WIDTH	18	$\begin{matrix} -0.018 \\ -0.061 \end{matrix}$
KEYWAY DEPTH	7	$\begin{matrix} +0.2 \\ 0 \end{matrix}$
KEY WIDTH	18	$\begin{matrix} 0 \\ -0.043 \end{matrix}$
KEY HEIGHT	11	$\begin{matrix} 0 \\ -0.110 \end{matrix}$

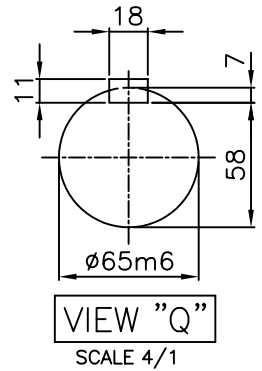

2. The type (1) - "TNB , TDB" is for HHI's standard products and it can be changed for customer's requirements or detail designing.

				TEFC STANDARD		
APPD BY	KANG K.J.	UNIT	MM	SUBJECT	KS Fr.225S TEFC	CAD PROJ \ FILE
CHKD BY	KIM O.J.	SCALE	1/15			MMSTDMTR/TJ2SAP51
CHKD BY	LEE N.D.	PROJEC'N	3rd Angle	TITLE OUTLINE THREE-PHASE INDUCTION MOTOR		
DSND BY	KIM RYANG GYU	DATE	2007.03.23			
				REF. NO	L2-Series	Sheet No. of
				DWG NO	TJ2SAP51	Revision No. 0

