



AC INDUCTION MOTOR DATA SHEET

Model No.or RFQ No.		Item No.		Rev. No. [0]			
Project Name		Project No.		Quantity sets			
GENERAL SPECIFICATION			PERFORMANCE DATA				
Frame Size	160L		Rated Output	15 kW 20 HP			
Type	HS		Number of Poles	4			
Enclosure(Protection)	Totally Enclosed (IP55)		Rotor Type	Squirrel Cage			
Method of Cooling	IC411(FC)		Starting Method*	<input checked="" type="checkbox"/> D.O.L <input type="checkbox"/> Y- Δ			
Rated Frequency	60 Hz		Rated Voltage	440 V	380 V 220 V		
Number of Phases	3		Current	Full Load	26.5 A 30.7 A 53.1 A		
Insulation Class	<input checked="" type="checkbox"/> F <input type="checkbox"/> B <input type="checkbox"/> H		Locked-rotor**	630 %	630 % 630 %		
Temp. Rise at full load (by resistance method)			Efficiency				
at 1.0 S.F 80 deg. C			50% Load 90.0 %				
Motor Location	<input checked="" type="checkbox"/> Indoor <input type="checkbox"/> Outdoor		75% Load 91.2 %				
Altitude	Less than 1000 meter		100% Load 91.0 %				
Relative Humidity	Less than 80 %		Power Factor(p.u)				
Ambient Temp.	40 deg. C (Max.)		50% Load 0.652				
Duty Type	Continuos (S1)		75% Load 0.750				
Service Factor	1.15		100% Load 0.815				
Mounting	<input checked="" type="checkbox"/> B3 <input type="checkbox"/> B5 <input type="checkbox"/> V1 <input type="checkbox"/> B3/B5		Speed at Full Load	1770 r.p.m			
Bearing	Type	Anti-Friction		Torque			
	DE/N-DE	6309ZZC3 / 6309ZZC3		Full Load	8.3 kg-m		
	Lubricant	Grease(Polyrex-EM)		Locked-rotor**	200 %		
External Thrust	Not applicable		Breakdown**	240 %			
Coupling Method	<input checked="" type="checkbox"/> Direct <input type="checkbox"/> V-Belt		Moment of Inertia (J)				
Shaft Extension	<input checked="" type="checkbox"/> Single <input type="checkbox"/> Double		Load(Max.) 12.750 kg-m ²				
Terminal Box	Main	<input type="checkbox"/> Steel <input checked="" type="checkbox"/> Cast Iron		Motor 0.090 kg-m ²			
	Aux.	<input type="checkbox"/> Yes <input checked="" type="checkbox"/> No		Sound Pressure Level (No-load & mean value at 1m from motor)			
	Location	Refer to Outline Drawing		74 dB(A)			
Application			Vibration 2.2 mm/sec (r.m.s)				
Area classification	Non-Hazardous		Permissible number of consecutive starts				
Type of Ex-Protection	Not applicable		Cold 3 times				
Applicable Standard	KS,IEC,NEMA MG1 Part30(Vpeak)		Hot 2 times				
ACCESSORIES			Paint	Munsell No.	4.0PB5.4/5.5(VL-451)		
			SUBMITTAL DRAWING			Outline Dimension Drawing \ Motor Weight(Approx.)	
					B3	227B2000AB06	135 kg
					B5	227B2020AB06	140 kg
					V1	227B2060AB06	140 kg
		B3/B5	227B2040AB06	140 kg			
			Main T-Box Ass'y	227B8008LA1			
SPARE PARTS			REMARK		High Efficiency		
			* For use on PWM VFD 10:1VT, 3:1CT@1.0S.F&F Temp. rise				
			Date	DSND	CHKD	CHKD	APPD
			2011-04-14	W.H.BACK	S. J. RA	O. J. KIM	J. H. KIM
			Note: Others not mentioned in this data sheet shall be in accordance with maker standard. Above technical data are only design values and shall be guaranteed with tolerance of applicable standard. Inspection and performance test shall be maker standard, if not mentioned. * In case of Inverter-Fed Motor, performance data is based on sine wave tests. ** Data is based on when the motor is supplied at rated voltage & frequency. and the data is expressed as a percentage of full-load value.				

Type	:	HS
Full Load Torque	:	8.3 Kg.m
Motor moment of Inertia (J)	:	0.090 Kg.m ²
Load moment of Inertia (J)	:	12.750 Kg.m ²

15 kW	4 P	60 Hz	
Speed at Full Load :		1770 RPM	
Rated Voltage	440V	380V	220V
Full Load Current	26.5A	30.7A	53.1A

SPEED VS TORQUE & CURRENT CURVE

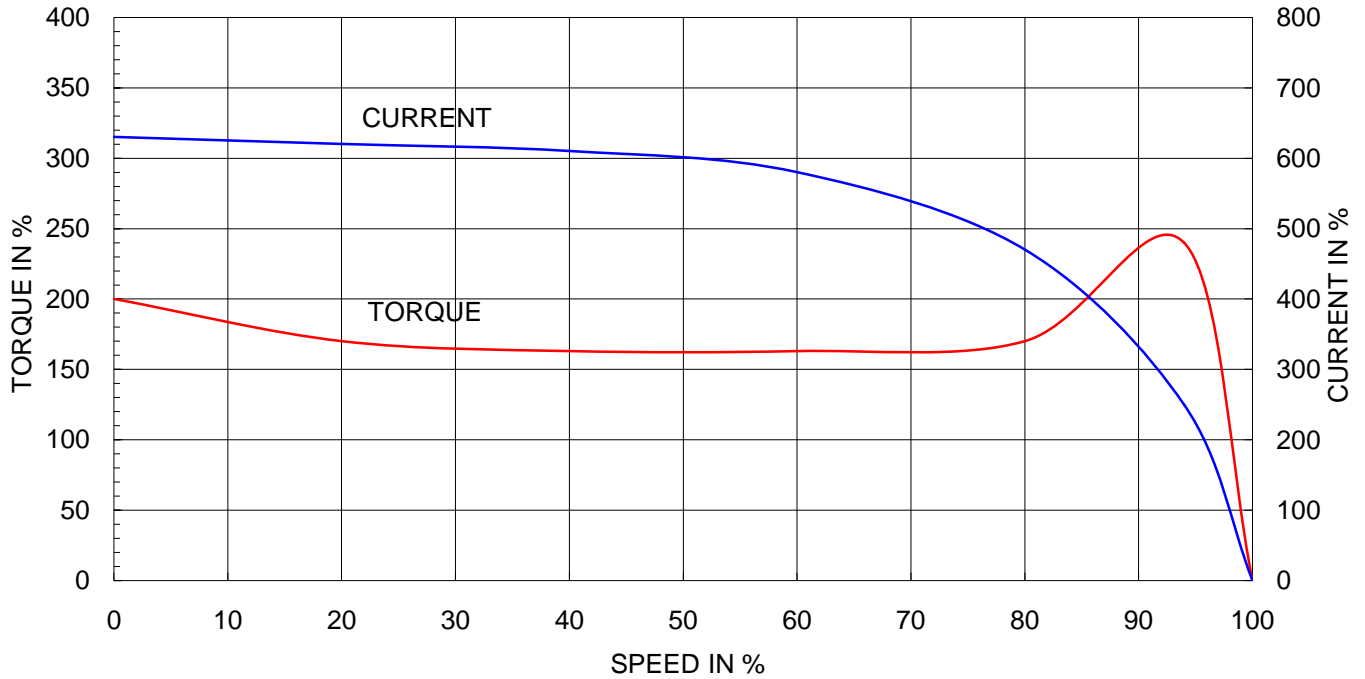

OUTPUT VS EFF., P.F & CURRENT CURVE

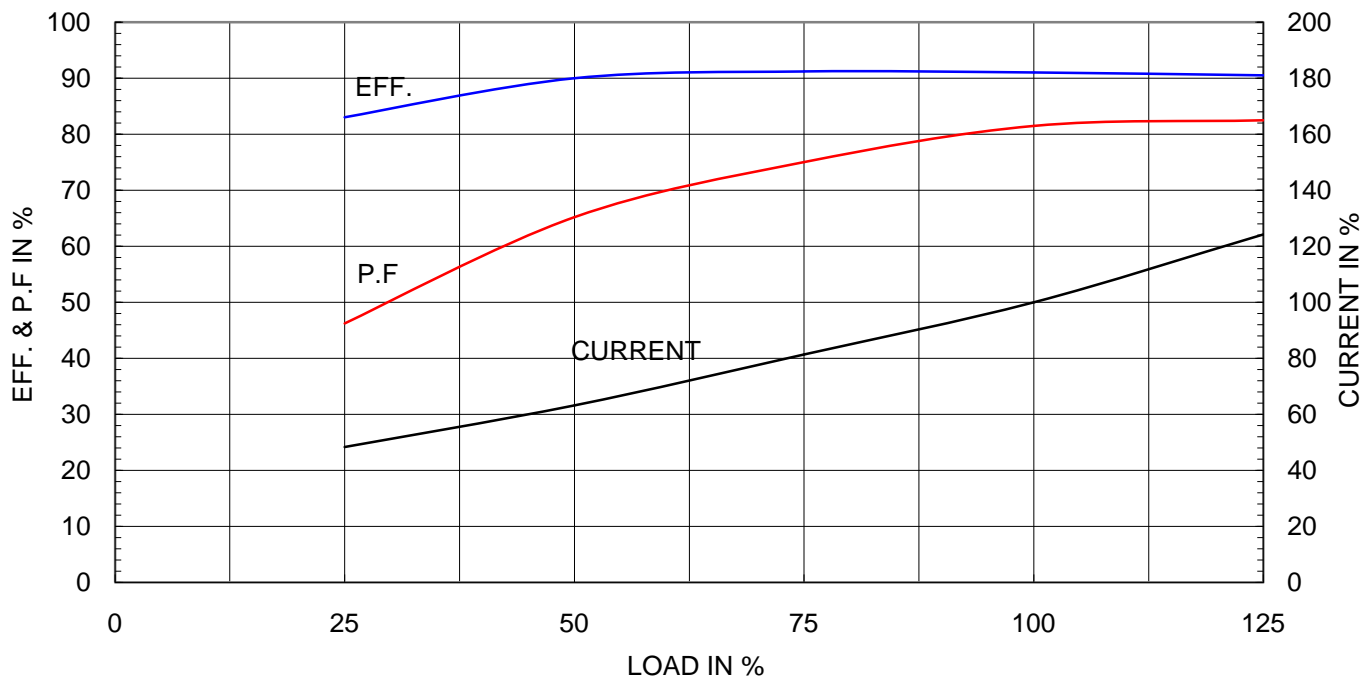



TEFC

THREE PHASE INDUCTION MOTOR

TYPE

HL, HLS

CAST IRON FRAME

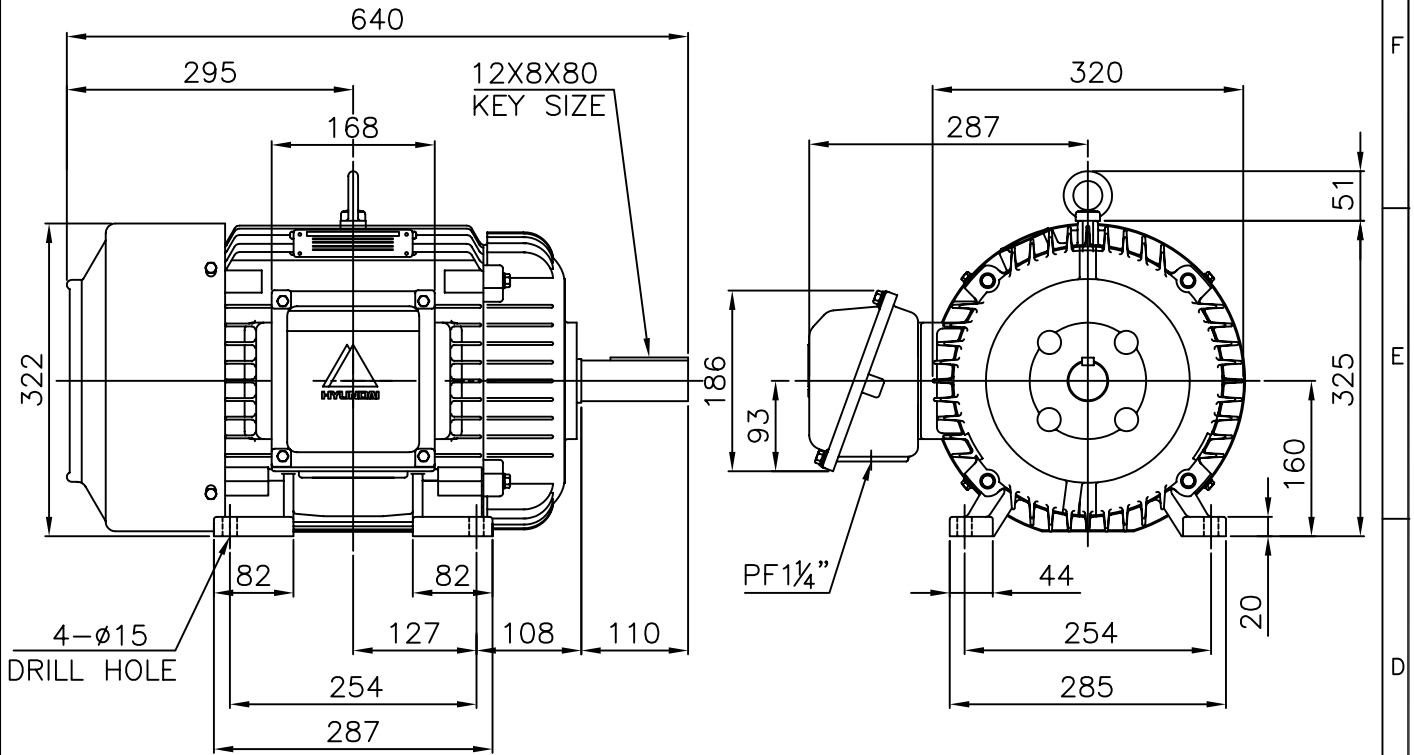

NOTE

1.TOLERANCE :

CENTER HEIGHT	160	$\begin{matrix} 0 \\ -0.5 \end{matrix}$
BASE HOLES	$\phi 15$	$\begin{matrix} +0.43 \\ 0 \end{matrix}$
SHAFT DIAMETER	$\phi 42$	$\begin{matrix} +0.018 \\ +0.002 \end{matrix}$
KEYWAY WIDTH	12	$\begin{matrix} 0 \\ -0.043 \end{matrix}$
KEYWAY DEPTH	5	$\begin{matrix} +0.2 \\ 0 \end{matrix}$

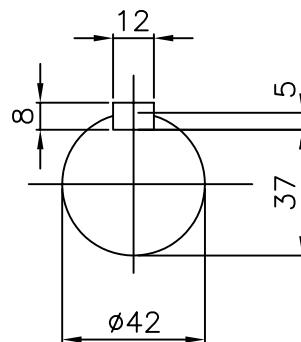

CAST IRON CONDUIT BOX

APPD BY	J. H. KIM	UNIT	mm	SUBJECT	KS 160L	CAD PROJ \ FILE
CHKD BY	Y. S. KIM	SCALE	1/8			XSDNKS\B2000AB06
CHKD BY	S. H. KO	PROJEC'N	3rd Angle	TITLE OUTLINE		
DSND BY	I. K. KIM	DATE	2002.10.27			
				REF. NO	B2000AB06	Sheet No. of
				DWG NO	227B2000AB06	Revision No. 0

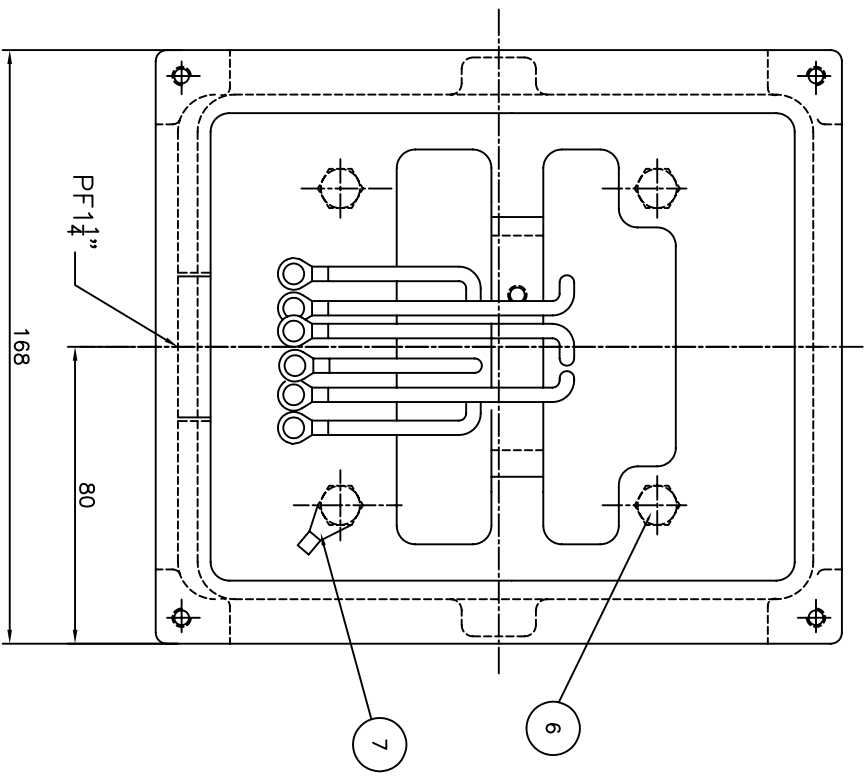
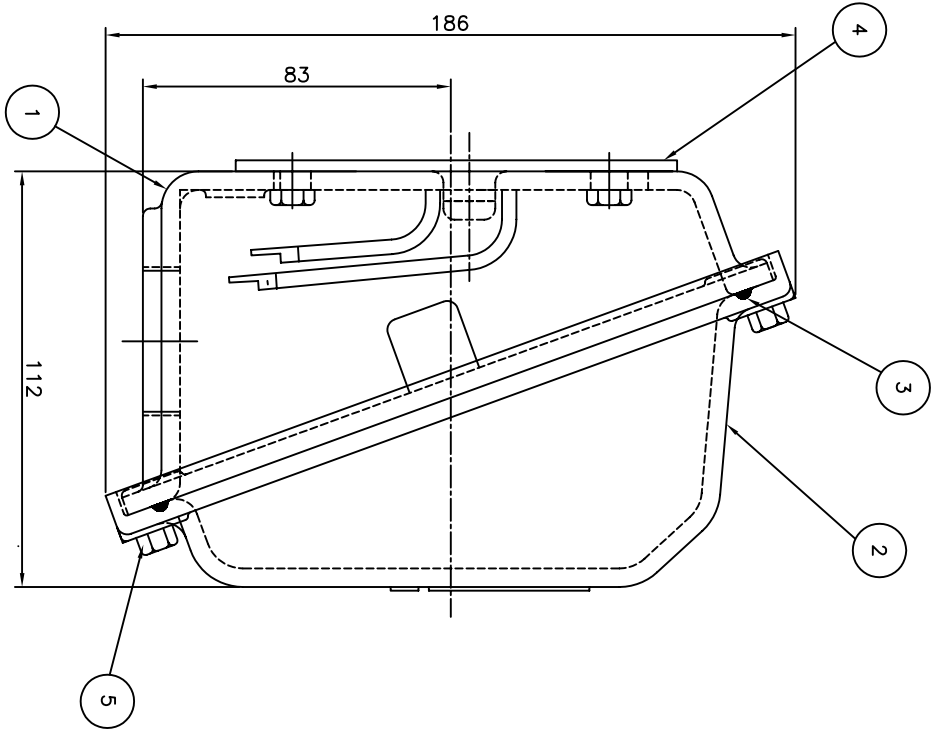

PT	DESCRIPTION	MATERIAL	DIMENSION	Q'TY
1	CONDUIT BOX	FC15	---	1
2	CONDUIT BOX COVER	FC15	---	1
3	O-RING / COVER	EPDM	φ4	1
4	BOX GASKET	NBR	---	1
5	COVER+BOX HEX BOLT	S45C	M6 X L20	4
6	BOX+FRAME HEX BOLT	S45C	M8 X L20	4
7	GROUND TERMINAL LUG	CU	---	1

REV	DATE	CONTENTS	REV'D BY	CHK'D BY	CHK'D BY	APP'D BY
1						
2						
3						
4						

Q'TY	DESCRIPTION	MATERIAL	DIMENSION	WEIGHT	PART NO.	REMARK	NO.
	APP'D BY KIM,Y.S	UNIT	MM				
	CHK'D BY KO,S.H	SCALE	1:1				
	CHK'D BY Y.J.HWANG	PROJEC'N	3*4 (3rd Angle)				
	DSND BY	DATE	2005.02.16				
	TITLE		TERMINAL BOX ASSEMBLY				
	REF. NO	227B8008LA1		Sheet No.	of		
	DWG NO	227B8008LA1		Revision No.	0		

