



AC INDUCTION MOTOR DATA SHEET

Model No.or RFQ No.		Item No.		Rev. No. [0]	
Project Name		Project No.		Quantity sets	
GENERAL SPECIFICATION			PERFORMANCE DATA		
Frame Size	280M		Rated Output	132 kW 175 HP	
Type	HS-132/2		Number of Poles	2	
Enclosure(Protection)	Totally Enclosed (IP55)		Rotor Type	Squirrel Cage	
Method of Cooling	IC411(FC)		Starting Method*	<input type="checkbox"/> D.O.L <input type="checkbox"/> Y- Δ	
Rated Frequency	60 Hz		Rated Voltage	440 V	380 V 220 V
Number of Phases	3		Current	Full Load	200.3 A 231.9 A 400.6 A
Insulation Class	<input checked="" type="checkbox"/> F <input type="checkbox"/> B <input type="checkbox"/> H			Locked-rotor**	700 % 700 % 700 %
Temp. Rise at full load (by resistance method)			Efficiency		
at 1.0 S.F 80 deg. C			50% Load 92.8 %		
Motor Location <input checked="" type="checkbox"/> Indoor <input type="checkbox"/> Outdoor			75% Load 94.1 %		
Altitude Less than 1000 meter			100% Load 94.5 %		
Relative Humidity Less than 80 %			Power Factor(p.u)		
Ambient Temp. 40 deg. C (Max.)			50% Load 0.912		
Duty Type Continuous (S1)			75% Load 0.915		
Service Factor 1.15			100% Load 0.915		
Mounting <input checked="" type="checkbox"/> B3 <input type="checkbox"/> B5 <input type="checkbox"/> V1 <input type="checkbox"/> B3/B5			Speed at Full Load 3570 r.p.m		
Bearing	Type	Anti-Friction		Torque	
	DE/N-DE	6314C3 / 6314C3		Full Load	36.0 kg-m
	Lubricant	Grease(Gadus S2 V 100 2)		Locked-rotor**	150 %
External Thrust Not applicable			Breakdown** 250 %		
Coupling Method <input checked="" type="checkbox"/> Direct <input type="checkbox"/> V-Belt			Moment of Inertia (J)		
Shaft Extension <input checked="" type="checkbox"/> Single <input type="checkbox"/> Double			Load(Max.) 14.375 kg-m ²		
Terminal Box	Main	<input type="checkbox"/> Steel <input checked="" type="checkbox"/> Cast Iron		Motor 2.400 kg-m ²	
	Aux.	<input type="checkbox"/> Yes <input checked="" type="checkbox"/> No		Sound Pressure Level (No-load & mean value at 1m from motor)	
Location Refer to Outline Drawing			92 dB(A)		
Application			Vibration 2.2 mm/sec (r.m.s)		
Area classification Non-Hazardous			Permissible number of consecutive starts		
Type of Ex-Protection Not applicable			Cold 3 times		
Applicable Standard KS,IEC,NEMA MG1 Part30(Vpeak)			Hot 2 times		
			Paint	Munsell No.	4.0PB5.4/5.5(VL-451)
ACCESSORIES			SUBMITTAL DRAWING		
			Outline Dimension Drawing \ Motor Weight(Approx.)		
			B3	TJ8MAC51	800 kg
			Main T-Box Ass'y 3M-016882		
SPARE PARTS			REMARK High Efficiency		
			*. For use on PWM VFD 10:1VT, 3:1CT@1.0S.F&F Temp. rise		
			Date	DSND	CHKD
			2010-05-28	R.G. KIM	O.J. KIM J.H. KIM K.J. KANG

Note: Others not mentioned in this data sheet shall be in accordance with maker standard.
 Above technical data are only design values and shall be guaranteed with tolerance of applicable standard.
 Inspection and performance test shall be maker standard, if not mentioned.
 * In case of Inverter-Fed Motor, performance data is based on sine wave tests.
 ** Data is based on when the motor is supplied at rated voltage & frequency. and the data is expressed as a percentage of full-load value.

Type	:	HS
Full Load Torque	:	36.0 Kg.m
Motor moment of Inertia (J)	:	2.400 Kg.m ²
Load moment of Inertia (J)	:	14.375 Kg.m ²

132 kW	2 P	60 Hz	
Speed at Full Load :			
3570 RPM			
Rated Voltage	440V	380V	220V
Full Load Current	200.3A	231.9A	400.6A

SPEED VS TORQUE & CURRENT CURVE

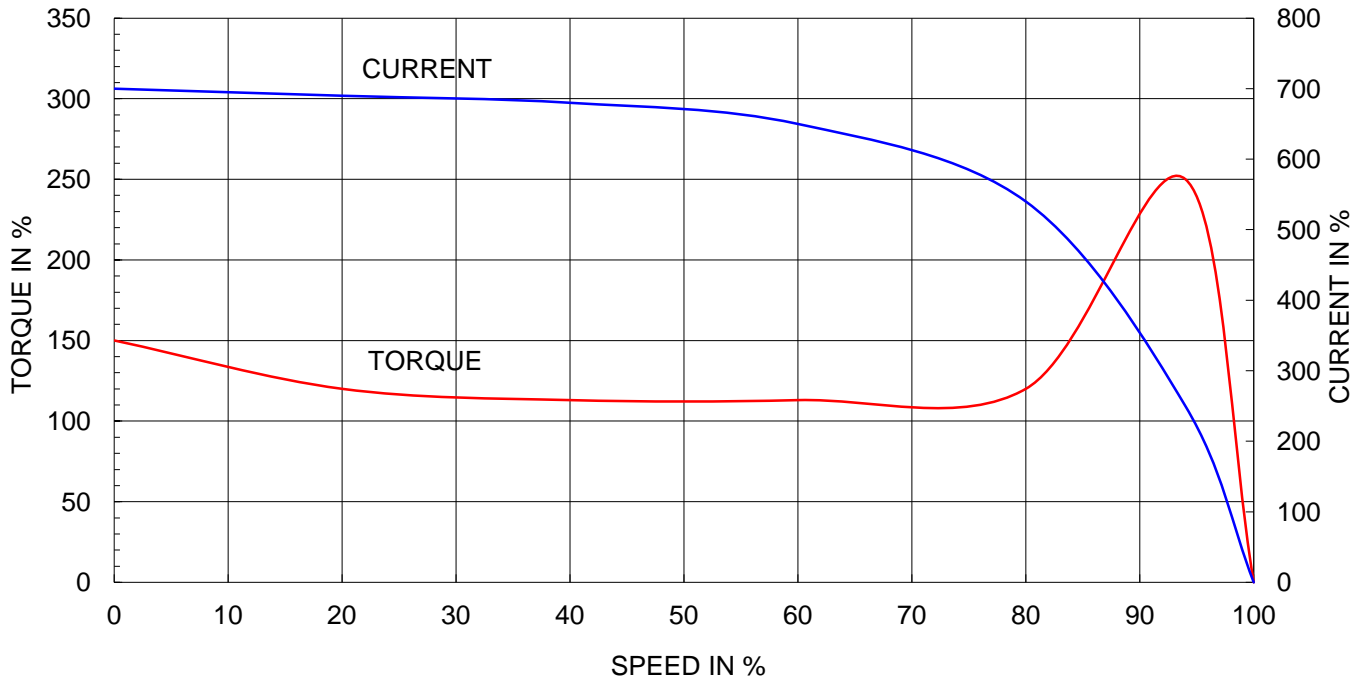

OUTPUT VS EFF., P.F & CURRENT CURVE

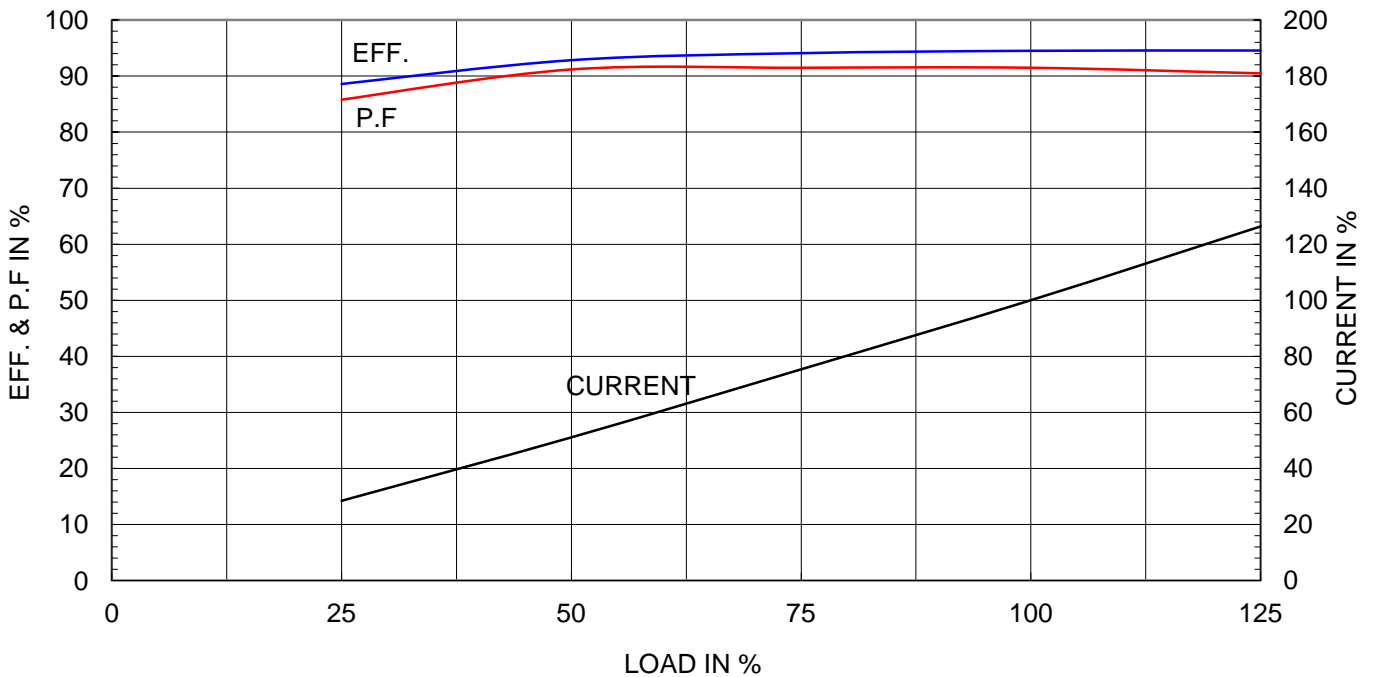

	<h1>TEFC</h1> <h2>THREE PHASE INDUCTION MOTOR</h2>	<h3>TYPE</h3>	⁽¹⁾ TNB , TDB CAST IRON FRAME
--	--	---------------	--

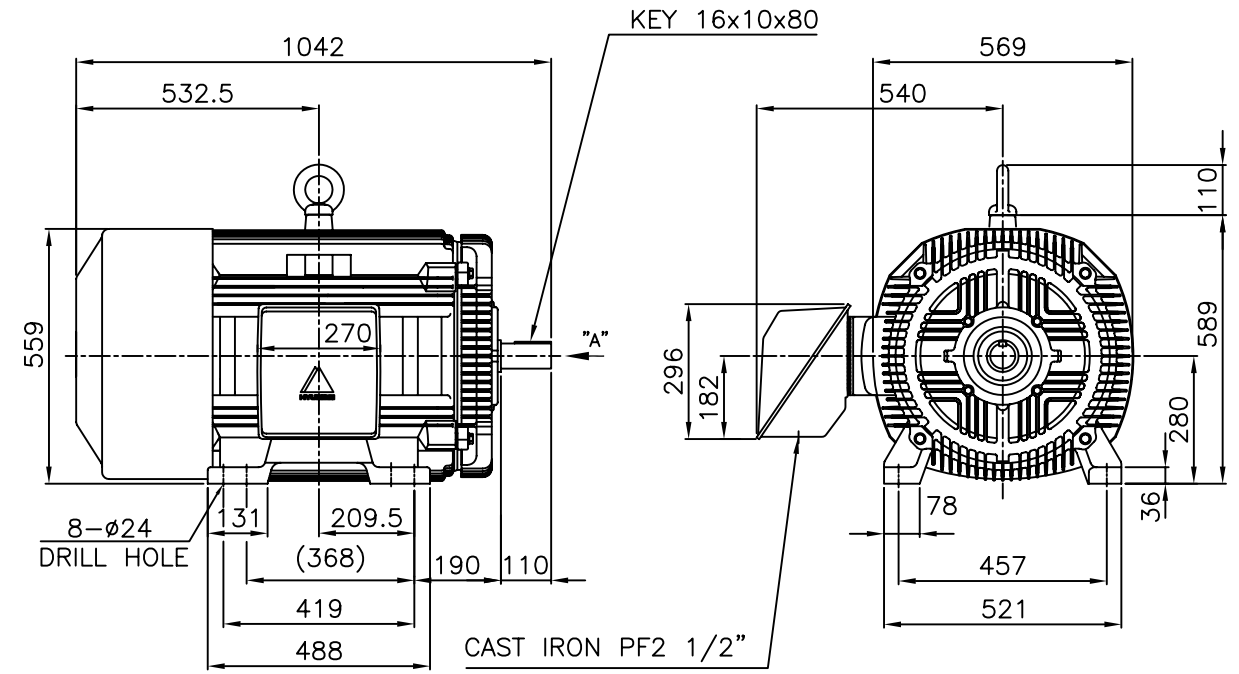

NOTE

1.TOLERANCE :

CENTER HEIGHT	280	$\begin{matrix} 0 \\ -1.0 \end{matrix}$
BASE HOLE	$\phi 24$	$\begin{matrix} +0.43 \\ 0 \end{matrix}$
SHAFT DIAMETER	$\phi 55$	$\begin{matrix} +0.030 \\ +0.011 \end{matrix}$
KEYWAY WIDTH	16	$\begin{matrix} -0.018 \\ -0.061 \end{matrix}$
KEYWAY DEPTH	6	$\begin{matrix} +0.2 \\ 0 \end{matrix}$
KEY WIDTH	16	$\begin{matrix} 0 \\ -0.043 \end{matrix}$
KEY HEIGHT	10	$\begin{matrix} 0 \\ -0.090 \end{matrix}$

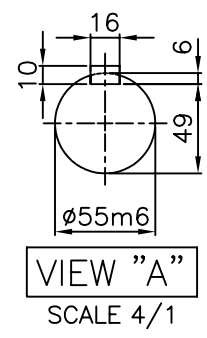

2.The type (1)-"TNB , TDB" is for HHI's standard products and it can be changed for customer's requirements or detail designing.

				TEFC STANDARD		
APPD BY	KANG K.J.	UNIT	MM	SUBJECT	KS Fr.280M TEFC	
CHKD BY	KIM O.J.	SCALE	1/17			CAD PROJ \ FILE
CHKD BY		PROJEC'N	3rd Angle	TITLE OUTLINE THREE-PHASE INDUCTION MOTOR		
DSND BY	KIM RYANG GYU	DATE	2003.08.30			
				REF. NO	L2-Series	Sheet No. of
				DWG NO	TJ8MAC51	Revision No. 0

